



Canada Meter Stamp Newsletter

No. 39

FALL 1993



Editor: Ross Irwin, 24 Marilyn Dr. Unit 903, Guelph, ON. N1H 8E9

Associate Editor and Treasurer: Dave Cooper, 35 South High St, Thunder Bay, ON., P7B 3K3.

Subscription fee: \$7.25 per year

EDITOR'S NOTES

This issue of the CMSG Newsletter is on National Cash Register postage registers. It is an area full of minor varieties and which does not appear to have been searched in detail. I trust you will compare your holdings with what is listed here so a more accurate listing may be made. Next issue will return to the NIXDORF area where many changes are taking place.

NATIONAL CASH REGISTERS - TYPES 40 - 41

Ross W. Irwin

Parcel post started in Canada in 1914. By 1930 it represented 40 percent of the total mail carried - 70 million pounds. Following the successful introduction of postage meters for the prepayment of postage commercial cash registers were introduced for the prepayment of postage on parcels of 4th class printed matter or parcel post and bulky matter prepaid at the letter rate.

Earlier, August 19, 1922, Realsilk Hosiery Mills wrote the Postmaster stating they had seen a postage due sticker and suggested the use of a cash register for mail.

National Cash Register Co. was not very interested in promoting their product. Postmaster Brown at Winnipeg requested a cash register to assist with parcels at Christmas. He wrote to mail order houses suggesting they appeal to Ottawa to get the system approved.

On September 3, 1925, Permit No. 100 was issued to the T.Eaton Co., Toronto, by the Secretary Branch of the Post Office Department for the use of a cash register to receive and record the amount of postage paid.

The Post Office Department Weekly Bulletin, and Sec 120 of the Canada Official Postal Guide, described the Regulation - "Postmasters are informed that in order to facilitate the handling and despatch of parcels posted at the large centres where extensive mailings are made, for delivery at places in the Dominion of Canada or in the United States, the Postage Paid in Cash system has been extended to parcel post. Each parcel mailed under the Postage Paid in Cash system will have affixed to it at the upper right hand corner of the address, where stamps are usually placed, and impression in red showing the amount of postage paid."

The Postal Guide gave additional information on the use of a register: "for prepayment of postage on packages of printed matter, samples, parcel post, and bulky first class matter mailed in quantity." And later, "Impressions are made on approved gummed paper tape showing the amount of postage with the place and date of mailing."

The postage register was delivered to the T. Eaton Co. on September 12, 1925, for their mail-order catalogue department. The machine was purchased by Eaton's. They operated a sub-post office which served only the company. The parcels were weighed on one floor and sent to the mail room on another floor.

A meeting was held October 20, 1925, to discuss the suggestion of the Deputy Post Master General to have permits granted by the Secretary Branch of the Post Office and that a commission of 1 percent be permitted. The commission was not discontinued until April 1, 1949. There was a 10 percent discount on the face value to redeem spoiled impressions. In 1927 the Postage Paid in Cash system was extended to parcels of the 3rd class.

Register numbers were originally assigned in blocks by towns and provinces. For example:- Halifax - 21 up, Toronto - 100 up, Ottawa - 400 up, Montreal - 500 up, Winnipeg 700 - up, Edmonton 900 - up, Vancouver 960 - up. In Hamilton, register 311 was assigned to a private firm while register 311A was used at the Hamilton post office.

The first three registers placed in service were:- No. 100 by T. Eaton Co., Toronto, Sep 3, 1925; No. 105 at Postal Terminal A, Toronto, Sep 28, 1925; and No. 104 at Adelaide St Post Office, Toronto, on Sep 30, 1925. The following year they were installed in other cities in Canada. By March 8, 1927, they were also in post offices at Halifax, Hamilton, Saskatoon and Moose Jaw.

The National Cash Register Co. of Dayton, Ohio, manufactured the postage register. Their Canadian agency was at 875 Bay St., Toronto, and later at 222 Lansdowne Ave., Toronto. There were two classes of postage registers sold in Canada - Class 1100 and Class 1900. The register number does not distinguish the machine class. The last register manufactured was in 1939 although some are still in use.

The Class 1100 postage register had a left and right register to record postage used. It produced adhesive labels for parcels although labels are infrequently found on letters. It printed values from 1c to \$9.99. The company used a deposit system with the post office and postage was purchased in certain specific such as \$200, \$500 or \$1000. An employee of the post office visited the companies on a weekly basis to check on postage use and to see they did not exceed the deposit. Class 1100 had the tape roll at the top and came out the bottom after passing through a die which printed the outline of the indicia. A second printing die printed the value. This is the reason so many values are out of sync. The cut illustrates the tape trail through a Class 1100 register.

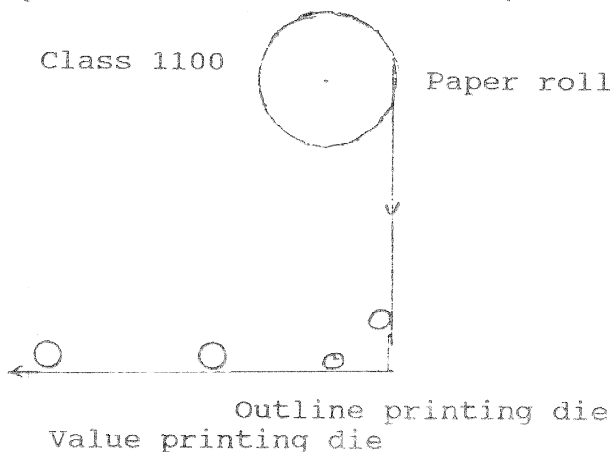

The paper tape is 28 mm wide and is cut off at 85 mm in length. The first labels were on white gummed paper printed by the National Cash Register Co. The Postal Guide stated the imprint should be in red.

The red imprint was changed to violet for parcel post but was retained to identify short paid mail. In April 1927 the Toronto Post Office was supplied with rolls having a

grey safety design showing the Crown, Maple Leaf and Canada Postage.

On May 28, 1930, the Post Office Department was asked to approve a register which would prepay a group of parcels and automatically number and identify the remaining parcels. It was pointed out that express companies already did this as competition. On July 25, 1930, a new machine having an "A" and "B" register was submitted and it was agreed to try it out at Montreal, Toronto and Winnipeg for parcels going to the same address. The total postage is noted on one parcel only, the number of parcels is also indicated on the indicia. This is illustrated below from the Postal Guide.

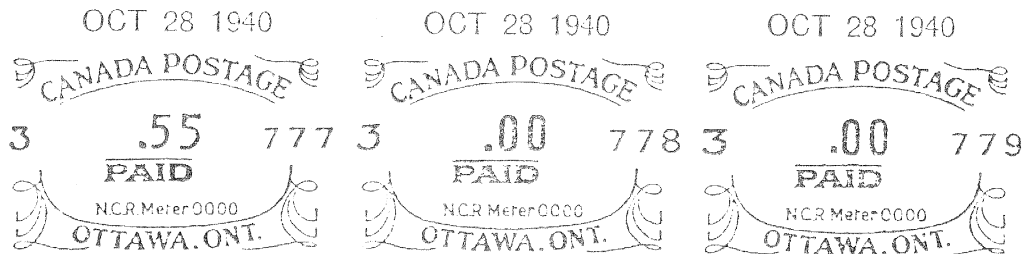

A revised machine, NCR Class 1900 R 1924 (1) and 1924 (3-1) was examined February 10, 1931 and approved for group mailing February 25, 1931. The approval was announced in the Weekly Bulletin of February 27, 1931, (file 13-1-26 Vol 1) for the prepayment of postage in bulk. This register was put on test with Metropolitan Life, Ottawa, December 18, 1931. The earliest known tape is May 1932 with permit 404 on yellow paper.

The Ohmer Fare Postage Register was also approved at the same time but the company decided not to market it in Canada.

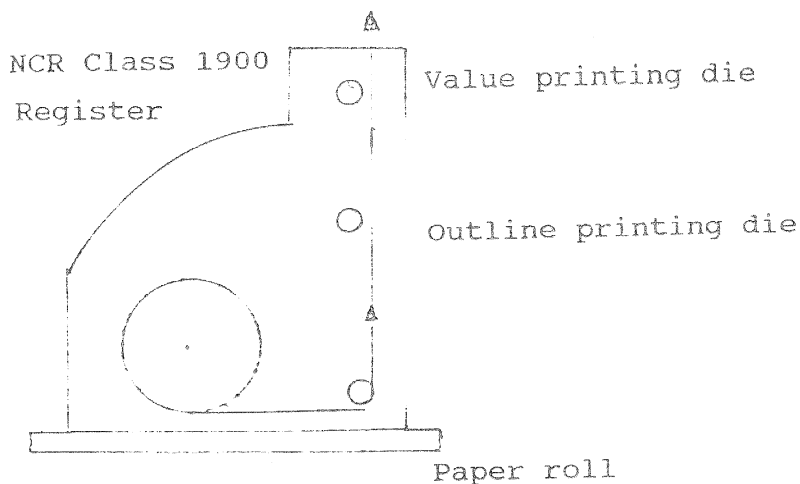

The new Class 1900 Model R-1924 (3-3) was introduced May 12, 1932. This new machine had a lock-out feature. The register weighed 90 pounds! Postage was accumulated to \$99,999. A key set the register for different amounts of postage. For example, in Toronto, 3 machines were set for \$200, 1 for \$1,000 and 1 for \$20,000. A record of postage used was recorded by the cash

register. The serial number of each parcel (0001 - 9999) was printed on the tape. The Class 1900 register had the roll of gummed paper at the bottom. It also went through a printing die which printed the outline of the indicia and then through a second printing die which printed the value etc. The tape came out of the top dry. The paper track is shown above.

On September 15, 1934 a new Class 1900 register was inspected where the lockout feature was eliminated. In this case the user had to have on deposit sufficient postage. The machine was approved on July 31, 1934. On the previous models the lock out device was set at round figures such as \$100, \$200, \$500 and could not be reset until all postage was used.

Renting of postage registers was approved March 26, 1931. Of 58 registers in Toronto 10 were owned and 34 were rented. Simpsons Ltd used 8 and Eaton's 10.

The advantage of the postage register over a postage meter was in speed and the paper came out the top dry. It was wetted on a pad and placed on the parcel based on the noted weight. For post offices there was not the need to put stamps of different denominations on a parcel, just put the cash in the drawer and register it. The Class 1900 registers were slower to operate than the Class 1100 and operators complained the rectangular shape of the label was more difficult to apply.

Register No 137 was used at Terminal A, Toronto, exclusively for placing a sticker on rated mail for postage due. Impressions were in red to distinguish them from the regular violet impressions. The register was placed in use May 1, 1928. It saved time on returned catalogues. In May 1928 labels accounted for \$909.39 and Postage Due stamps \$1168.00 at Terminal A. The register was rebuilt in 1939 and has a slightly different indicia. It continued in use into the 1950's. The Class 1900 label was 54 mm wide and cut off at 46 mm.

The number of postage registers in service varied greatly. For example at Christmas many more were rented and put into service. Numbers in use were: 1934 - 138; 1951 - 156; 1952 - 169; 1959 - 121; 1960 - 129; 1961 - 119; 1962 - 113; 1964 - 125; 1968 - 92; 1971 - 92. In 1971 there were still 92 registers in use - 26 by Eaton's, 24 by Simpson's, and 22 additional registers at Christmas for 11 users. Postage generated by registers was about \$6 million

In April 1942 there were 23 postage registers in post offices across Canada. These were as follows:- Toronto (2), Montreal, Winnipeg (3), Vancouver (3), Ottawa (2), Calgary, Hamilton, Regina (2), Edmonton, Halifax, London, Windsor (since 1936), Moose Jaw, Saskatoon since 1926, Victoria and Brantford. By 1964 the Post Office only operated 2 registers, the bulk was sold through Crown Assets in 1960.

LISTING OF REGISTER LABELS

The system described below is an attempt to derive a simple classification for register labels. It proved to be somewhat of a waste of time as the NCR registers have too much variation. I have elected to stay with the original system which in general looks this way. Breaking the tape into four sections.

40.1	CPP	\$	N T Y	Date	1	2	3	4
40.2	Date	CPP	\$	N T Y	4	1	2	3
40.3	CPP	Date	N T Y	\$	1	4	3	2
40.4	N T Y	\$	CPP	Date	3	2	1	4

The numbers at the right show there may be slippage of some form in the installation of the tape drive inasmuch as 40.1 and 40.2 have slipped one group and 40.3 and 40.4 have slipped two groups. It is difficult to know how or why

this occurred. I have assigned 40.5 to the Postage Due register as a distinct type. There is much variation in type font style and size as well as the way the town is printed. These modifications would be classified by a third digit; ie 41.1.1, should we get ambitious to do it.

The Type 41 has much variety but the variety tends to be in the type font and the third section which prints the rate and parcel number. I have elected to break this Type 41 into just three classes - CANADA POSTAGE; POSTES CANADA; and the Postage Due register. Any better ideas?

The accompanying table has a number of problems. The obvious one is I forgot to change the page length of my paper and the breaks came at odd places (You can make your notes here). I have a limited number of specimens to examine and only those I own or have a photocopy of are classified. In the midst of the work I changed some of the numbers and may not have got them all changed. That is, the chart cannot be guaranteed for accuracy.

I hope you will look over the specimens you own and using the system of classification shown here correct my listings and add to them. These registers have been in use from 1925 to the present and have undergone many modifications. I don't know if we will ever get a complete listing, but let's try.

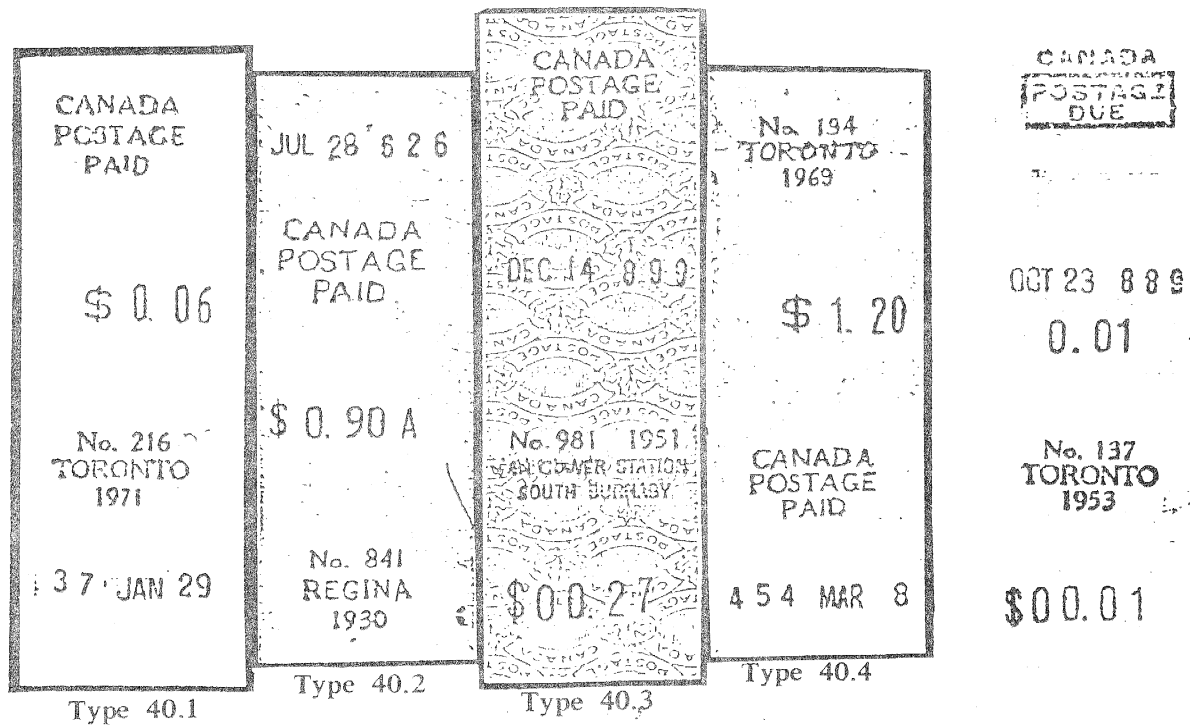

NATIONAL CASH REGISTER TAPES
KEY TO CLASSIFICATION
TYPE 40

CANADA POSTAGE PAID
\$ 45
No. 512 REGINA 1939
721 Feb. 18

A The Class 1100 postage register tape as shown in the Postal Guide is conveniently broken into four sections. In the example, sections A, C and D are all printed at once by the outline printing die. Section B is printed by the value printing die. There is much variation as noted below.

B One might also hypothesis that differences in the indicia are due to carelessness in inserting the printing die so that instead of starting with Section A the die has been rotated and starts with Section D. However, having made that observation we must also note that the parcel number is before the date in once instance and after it in another.

C We need some new knowledge to resolve this problem, or we just accept the indicia as printed, which is what I have done here.

D To save space I have adopted some letters to identify minor differences in the indicia
a - small capital letters with serifs
b - large capital letters with serifs
c - capital letters sans-serif
. - period in the Section

Section A

- 1 - CANADA/POSTAGE/PAID
- 2 - CANADA POSTAGE/PAID/PORT PAYE
- 3 - CANADA/POSTAGE PAID/Port Paye
- 4 - CANADA/Postage Paid/Port Paye
- 5 - Canada/Postage Paid/Port Paye
- 6 - CANADA/(POSTAGE DUE), no serifs
- 7 - CANADA/(Postage Due), serifs
- 8 - Canada Postage/PAID/House of Assembly/P.O.
- 9 - PN MD (PN is parcel number)
- 10 - MD PN
- 11 - No./TOWN/Y (No. is the PPC number)
- 12 - Canada/Postage Paid./Port Paye.

Section B

- 1 - \$0.00
- 2 - 0.00
- 3 - .00
- 4 - \$0.00A
- 5 - \$0.00B
- 6 - CANADA/POSTAGE/PAID
- 7 - MD PN

Section C

- 1 - No./TOWN/Y
- 2 - No./TOWN, PR/Y
- 3 - No./TOWN
- 4 - \$0.00A
- 5 - 0.00A
- 6 - CANADA/POSTAGE/PAID
- 7 - No./Y/TOWN
- 8 - No. Y/TOWN

Section D

- 1 - PN MD
- 2 - \$00.00
- 3 - No./TOWN/Y
- 4 - CANADA/POSTAGE/PAID

TYPE 41

The Class 1900 postage register tape is shown. For classification purposes this tape is conveniently broken into six sections.

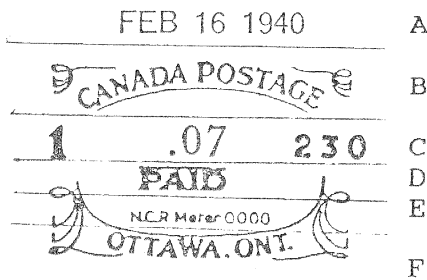

Again, Sections B, D, E and F are printed by the outline die. In many instances these are difficult to read because the operator fails to ink both dies, and the postage one is more important.

Another point is whether Sections D and E should be combined inasmuch as the Postage-Paid-in-Cash (PPC) number tends to be between the sections as there is too little space to be used as shown in the example. I have chosen to attach the PPC number to Section E, even if it is in another Section.

Section A

- 1 - Date - MDY

Section B

- 1 - CANADA POSTAGE, with serifs
- 2 - CANADA POSTAGE, sans serifs
- 3 - POSTES - CANADA, with serifs
- 4 - CANADA POSTAGE/DUE

Section C

- 1 - -.00A PN3(3 digits)
- 2 - -.00 PN4
- 3 - .00B PN3
- 4 - .00 PN3
- 5 - .00 PN4
- 6 - N -.00 PN3 (N is group number)
- 7 - N -.00 PN4
- 8 - A -.00Wh PN3

Section D

- 1 - PAID with serifs
- 2 - PAID sans serifs
- 3 - No line above PAID
- 4 - Amount to be Collected
- 5 - Port Paye
- 6 - PORT PAYE

Section E

- 1 - N.C.R. Meter
- 2 - No./Port Paye
- 3 - MCR Meter
- a - large numeral; b small numerals

Section F

- 1 - TOWN, PROV. with serifs
- 2 - TOWN, PROV. sans serifs
- 3 - TOWN Y
- 4 - TOWN, CANADA
- 5 - TOWN
- a - lower case
- 5 - MD PN

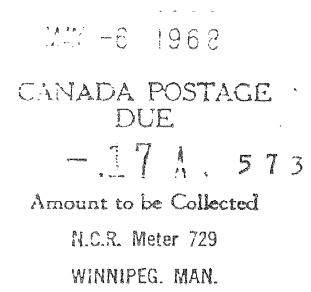
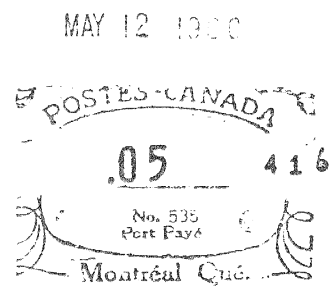
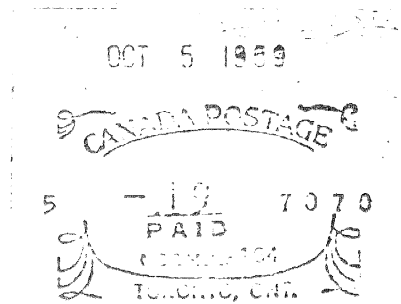

LISTING OF NCR REGISTERS

PPC No.	TOWN	YEAR	USER	TYPE	A	B	C	D	E
1	BELLEVILLE	1962		41.1	1	1	8	2	1
1	COOKSVILLE	1960	REXALL DRUGS	40.1	1a	1	1	1	
1	GEORGETOWN	1937		41.1	1	1	5	1	1
1	GEORGETOWN, ONT.	1937		41.1	1	1	1	1	1
1	GEORGETOWN, ONT.	1941		41.1	1	1	2	2	1
1	SCARBORO	1965	W.J.GAGE	41.1	1	1	1	1	1
1	SCARBORO, ONT.	1965	W.J.GAGE	41.1	1	1	1	1	1
1	SCARBOROUGH	1967	W.J.GAGE	41.1	1	1	1	1	1
1	SCARBOROUGH	1966	W.J.GAGE	41.1	1	1	5	2	1
1	SCARBOROUGH, ONT.	1972	W.J.GAGE	41.1	1	1	1	2	1
1	ST. CATHARINES	1952		41.1	1	1	8	2	1
1	WESTON, ONTARIO		EATONS	41.1					
1	WOODSTOCK, ONT.	1964	YORK KNITTING MILLS	40.4	11	1	6c	1	
2	OSHAWA, ONT.	1935	GENERAL MOTORS	41.1	1	1	5	1	1
2	OSHAWA, ONT.	1935	GENERAL MOTORS	41.1	1	1	1	1	1
2	OSHAWA, ONT.	1940	GENERAL MOTORS	41.1	1	1	5	2	1
2	OSHAWA, ONT.	1941	GENERAL MOTORS	41.1	1	1	4	2	1
2	OSHAWA, ONT.	1949	GENERAL MOTORS	41.1	1	1	4	1	1
2	OSHAWA, ONT.	1952	GENERALMOTORS	41.1	1	1	3	2	1
4	OSHAWA, ONT.	1948	BEDMARCK HARDWARE	41.1	1	1	1	2	1
4	OSHAWA, ONT	1949		41.1	1	1	5	2	1
8	ST. JOHN								
11	TORONTO, ONT.	1964		41.1					
20	TORONTO, ONT.	1966		41.1	1	1	2	2	3
21	TORONTO, ONT.	1966		41.1	1	1	2	2	1
22	HALIFAX	1939	SIMPSONS	40.1	1c	1	1	1	
22	HALIFAX, N.S.	1960	SIMPSONS	41.1					
23	HALIFAX, N.S.	1960	SIMPSONS	41.1	1	1	2	2	1
24	HALIFAX	1943	MEAKINS & SONS	40.2	10	6c	4	3	
24	HALIFAX, N.S.	1960	SIMPSONS	41.1					
25	HALIFAX		SIMPSONS						
26	HALIFAX		EATONS						
27	HALIFAX, N.S.	1954		41.1	1	1	9	2	2
28	HALIFAX, N.S.			41.1					
32	HALIFX, N.S.	1955		41.1	1	1	5	2	1
??	HALIFAX	1947		40.2	10	6	4	3	
41	TRURO		STANFIELDS						
73									
74									
75									
76									
77	MONCTON, N.B.			41.1					
78	MONCTON, N.B.	1941		41.1	1	1	1	2	2
79	MONCTON		EATONS						
80	MONCTON, N.B.	1978		41.1	1	1	2	2	1
81									
82	MONCTON, N.B.	1964	EATONS	41.1	1	1	2	2	1
83	MONCTON, N.B.	1963	EATONS	41.1	1	1	2	2	1
84	MONCTON		EATONS						
85	MONCTON, N.B.	1967	EATONS	41.1	1	1	2	2	1
86	MONCTON, N.B.	1969	EATONS						
87	MONCTON, N.B.	1972	EATONS	41.1	1	1	5	2	1

88									
89									
90									
91									
92									
93									
94									
95									
96									
97									
98									
99									
100	TORONTO	1926		40.1	1b.	1	1	1	
100	TORONTO, ONT.	1940	EATONS	41.1					
101									
102	TORONTO	1941		40.1	1c	1	1	1	
103	TORONTO	1925		40.1	1b	1	1	1	
103	TORONTO, ONT.	1941		41.1					
103	SCARBOROUGH, ONT.	1970	W.J.GAGE	41.1	1	1	2	2	1
103	SCARBOROUGH, CANADA	1973	W.J.GAGE	41.1	1	1	2	2	1
104	TORONTO	1928	CANADA POST	40.2	10	6c	4	3	
104	TORONTO	1930	CANADA POST	40.2	10	6a.	4	3	
105	TORONTO	1930	CANADA POST	40.2	10	6a.	4	3	
105	TORONTO	1937		40.2	10	6a	4	3	
106									
107	TORONTO, ONT.	1963		41.1	1	1	5	2	1
108	TORONTO, ONT.	1966	EATONS	41.1	1	1	1	1	1
109	TORONTO, ONT.	1938	EATONS	41.1	1	1	5	1	1
109	SCARBOROUGH, ONT.	1969	W.J.GAGE	41.1	1	1	3	2	1
110	TORONTO, ONT.	1942	EATONS	41.1	1	1	5	2	1
110	TORONTO	1959	EATONS	40.1	1b.	1	1	1	
110	SCARBOROUGH, ONT.	1970	W.J.GAGE	41.1	1	1	3	2	1
111	TORONTO, ONT.	1936	EATONS	40.1	1b	1	1	1	
111	TORONTO	1942		41.1	1	1	5	2	1
112	TORONTO	1928		40.2	10	6b.	4	3	
112	TORONTO	1947		40.2	10	6a	4	3	
112	TORONTO	1952		40.2	10	6a	4	3	
113	TORONTO	1947		40.1	1a	1	1	1	
114	TORONTO	1934		40.1	1b	1	1	1	
115									
116	TORONTO	1937		40.1	1b	3	1	2	
116	REXDALE, ONT.	1977		41.1	1	1	2	4	1
117	TORONTO	1936		40.1	1b.	1	1	1	
117	MT. DENNIS	1947		40.1	1a	1	1	1	
118	TORONTO	1931		40.1	1b	3	1	2	
118	TORONTO	1933		40.1	1b	1	1	1	
118	TORONTO	1959	RYERSON PRESS	40.1	1a	1	1	1	
118	TORONTO	1973	MCMILLAN CO	40.1	1a	3	1	2	
119	TORONTO	1927		40.1	1a.	1	1	1	
120	TORONTO			40					
121	TORONTO	1937		40.1	1c	1	1	1	
121	TORONTO	1947		40.1	1a	1	1	1	
121	TORONTO, ONT.	1961		41.1	1	1	1	2	1
122	TORONTO	1938		40.1	1a	1	1	1	
123									
124	TORONTO	1928		40.1	1a	1	1	1	
125									
126	TORONTO	1935		40.1	1a.	1	1	1	

126	TORONTO, ONT.	1970	41.1	1	1	4	2	1
127								
128	TORONTO	1948 H.A. KIDD CO	40.1	1a.	1	1	1	
128	TORONTO	1950	40.1	1a.	1	1	1	
129	TORONTO	1938	40.1	1a.	1	1	1	
129	TORONTO, ONT.	1962	41.1	1	1	2	2	1
130								
131								
132	TORONTO	1928	40.1	1a	1	1	1	
133	TORONTO	1930	40.1	1a	1	1	1	
133	TORONTO	1931	40.1	1a	1	1	1	
133	TORONTO	1934	40.1	1a	1	1	1	
134								
135								
136								
137	TORONTO	1933 CANADA POST	40.6	7	7	1	2	
137	TORONTO	1935 CANADA POST	40.6	6	7	1	2	
137	TORONTO	1936 CANADA POST	40.6	6	7	1	2	
138								
139								
140								
141	TORONTO	1941	40.1	1c	1	1	1	
141	TORONTO	1943	40.1	1c	1	1	1	
141	TORONTO	1948	40.1	1c	3	1	2	
142								
143	TORONTO	1937	40.1	1c	1	1	1	
143	TORONTO	1942	40.1	1a	1	1	1	
143	TORONTO	1953	40.1	1c	1	1	1	
143	TORONTO, ONT.	1954	41.1	1	1	2	2	1
143	TORONTO	1955	40.1	1a	1	1	1	
144								
145	TORONTO	1937	40.1	1a	1	1	1	
145	TORONTO	1945	40.1	1a	1	1	1	
145	TORONTO, CANADA	1962	41.1	1	1	1	1	1
146	TORONTO	1948	40.1	1a	1	1	1	
147								
148	TORONTO		40.1	1a	1	1	1	
148	TORONTO, ONT.	1970	41.1	1	1	4	1	1
149	TORONTO	1934	40.5	8	1	1	1	
150	TORONTO	1931	40.1	1a	1	1	1	
150	TORONTO, ONT.	1936	41.1	1	1	5	1	1
150	TORONTO, ONT.	1957 WARNER LAMBERT	41.1	1	1	1	2	1
150	SCARBOROUGH, ONTARIO	1968 WARNER LAMBERT	41.1	1	1	1	2	1
151								
152								
153								
153	TORONTO	1931	40.1	1a	1	1	1	
154	TORONTO	1945	40.1	1a	1	1	1	
154	TORONTO	1954	40.4	11	1	6a	1	
154	TORONTO	1958	40.1	12	3	6a	2	
154	TORONTO, ONT.	1963 W.E. COUTTS CO	41.1	1	1	3	1	1
154	TORONTO, ONT.	1965 W.E. COUTTS CO	41.1	1	1	1	2	1
155								
156								
157	TORONTO, ONT.	1933	41.1					
158	TORONTO, ONT.	1966 EATONS	41.1	1	1	2	1	1
158	SCARBOROUGH, ONT.	1970 W.J. GAGE	41.1	1	1	2	2	1

158	SCARBOROUGH, ONT.	1971	W.J.GAGE	41.1	1	1	3	2	1
159	TORONTO, ONT.	1953		41.1	1	1	2	2	1
160									
161	TORONTO, ONT.			41.1					
162									
163	TORONTO	1931		40.1	1a	1	1	1	
163	TORONTO, ONTARIO	1952		41.1	1	1	5	2	1
164	TORONTO, ONT.	1959		41.1	1	1	2	2	1
165	TORONTO, ONT.	1962		41.1	1	1	2	2	1
166	TORONTO, ONT.	1944	EATONS	41.1	1	1	5	2	1
166	SCARBOROUGH, ONT.	1973	W.J.GAGE	41.1	1	1	3	2	1
167	as above but 1/2¢ rate			41.1	1	1	3	2	1
167	TORONTO, ONT.	1969		41.1	1	1	2	2	1
168	TORONTO, ONT.	1960		41.1	1	1	1	1	1
169	TORONTO, ONTARIO	1931		41.1	1	1	2	1	1
169	TORONTO, ONT.	1949	REGAL STATIONERY	41.1	1	1	2	1	1
169	TORONTO, ONT.	1958	EATONS	41.1	1	1	2	2	1
169	TORONTO, ONTARIO	1971		41.1	1	1	1	2	1
171									
172	TORONTO, CAN.	1944		41.1					
173	TORONTO, ONT.	1945		41.1					
174									
175									
176	TORONTO, ONT.	1964		41.1	1	1	2	2	1
177	TORONTO, ONTARIO	1963		41.1	1	1	2	2	1
178	TORONTO, ONT.	1971		41.1	1	1	4	1	1
179	TORONTO, ONT.	1970		41.1	1	1	4	1	1
180	TORONTO, ONT.	1945	EATONS	41.1	1	1	1	1	1
181	TORONTO, CAN.	1966							
182	TORONTO	1954		40.2	10	6c	4	3	
182	TORONTO	1957		40.2	10	6c	4	3	
183	TORONTO, ONT.	1965							
184	TORONTO, ONT.	1944							
185	TORONTO, ONT.	1961		41.1	1	1	2	2	1
186	TORONTO, ONT.	1964		41.1	1	1	2	2	1
187	TORONTO, ONT.	1946		41.1	1	1	2	2	1
188	TORONTO, ONT.	1951							
189	TORONTO, CANADA	1946	NORMS STATIONERY	41.1	1	1	1	1	1
189	TORONTO, ONT.	1961		41.1	1	1	4	1	1
190									
190	TORONTO, ONT.	1949		41.1	1	1	5	2	1
191									
192	TORONTO, ONT.	1966		41.1	1	1	2	2	1
193	TORONTO, ONT.	1960		41.1	1	1	5	2	1
194									
195	TORONTO, ONT.	1951		41.1	1	1	2	2	1
196									
197	TORONTO, ONT.	1955		41.1	1	1	1	1	1
198									
199									
200	TORONTO, ONT.	1967	EXQUISITE FORM	41.1	1	1	5	2	1
201	TORONTO, ONT.	1971	NCR	41.1	1	1	5	2	1
202									
203									
204	TORONTO, ONT.	1973		41.1	1	1	5	2	1
205									
206	TORONTO, ONT.	1967		41.1	1	1	2	2	1

207									
208	TORONTO, ONT.	1957	41.1	1	1	2	2	1	
208	TORONTO, ONT.	1959	41.1	1	1	6	2	1	
209									
210									
211	TORONTO, ONT.	1965	41.1	1	1	5	2	1	
212									
213									
213	WINNIPEG	1937	40.1	1b	1	1	1		
214	TORONTO, ONT.	1960	41.1	1	1	2	2	1	
215									
216	TORONTO	1971	40.1	1	1	1	1		
217	TORONTO, ONT.	1972	41.1	1	1	2	2	1	
218	TORONTO, ONT.	1972	41.1	1	1	2	2	1	
219	TORONTO, ONT.	1973	41.1	1	1	5	2	1	
220									
221	SHERBROOKE								
256	BRANTFORD	1934	40.2	10	6a	4	3		
256	BRANTFORD	1950	41.1	1	1	3	2	1	
256	BRANTFORD, ONT.	1956	41.1	1	1	7	2	1	
311	HAMILTON	1928	40.2	10	6b.	4	3		
311	HAMILTON	1930	40.2	10	6b.	4	3		
311	HAMILTON	1931	40.2	10	6b.	4	3		
311	HAMILTON, ONT.	1938	41.1	1	1	1	1	3	
311	HAMILTON, ONT.	1942	41.1	1	1	7	2	1	
311	HAMILTON, ONT.	1942	41.1	1	1	1	2	3	
311A	HAMILTON	1926	40.1	1a	2	1	1		
311A	HAMILTON, ONT.	1948	41.1	1	1	1	2	1	
311A	HAMILTON, ONT.	1953	41.1	1	1	1	2	1	
312	HAMILTON		40						
314	TORONTO, ONT.		41.1	1	1	4	2	1	
341	KITCHENER	1931	40.1	1a	1	1	1		
341	WATERLOO	1960	40.1	1a	1	1	1		
342	KITCHENER	1951							
361	LONDON	1930	40.2	10	6a	5	3		
361	LONDON	1935	40.2	10	6a	5	3		
362	LONDON	1942	40.1	1a	1	1	1		
363	LONDON, ONT.	1947	41.1						
364	LONDON	1930	40						
401	OTTAWA	1928	40.2	10	6a.	4	3		
401	OTTAWA	1931	40.2	10	6a	4	3		
402	OTTAWA	1952	40.1	1a	1	1	1		
402	OTTAWA	1960	41.1	1	1	7	2	1	
403	OTTAWA	1934	40.2	10	6a	4	3		
403	OTTAWA	1949	40.2	10	6a	4	3		
404	OTTAWA, ONT.	1932	41.1	1	1	5	1	1b	
404	OTTAWA, ONT.	1934	41.1	1	1	5	1	1b	
404	OTTAWA, ONT.	1938	41.1	1	1	1	2	1	
404	OTTAWA, ONT.	1938	41.1	1	1	1	1	1	
404	OTTAWA, ONT.	1944	41.1	1	1	5	1	1	
404	OTTAWA, ONT.	1949	41.1	1	1	5	1	1	
404	OTTAWA, ONT.	1951	41.1	1	1	1	2	1	
404	OTTAWA, ONT.	1961	41.1	1	1	1	2	1	
404	OTTAWA, ONT.	1971	41.1	1	2	2	2	3	
404	OTTAWA, ONT.	1975	41.1	1	2	2	2	1	
405	OTTAWA, ONT.	1952	41.1	1	1	1	2	1	
405	OTTAWA, ONT.	1952	41.1	1	1	1	2	1	
405	OTTAWA, ONT.	1954	41.1	1	1	8	2	1	

501	MONTREAL	1926	H. BIRK	40.1	4	3	1	2	
502	MONTREAL		DUPUIS FRERES						
503	MONTREAL, QUE.	1963		41.1	1	1	1	2	1
504	MONTREAL, QUE.			41					
505									
506	MONTREAL	1939	TOOKE BROS	40.1	2	1	1	1	
507	MONTREAL		RALSTON TAILORS						
508	MONTREAL	1943	GREENSHIELDS	40.1	5	1	1	1	
508	MONTREAL, QUE.	1963		41.1	1	1	1	5	2
509									
510	MONTREAL	1936		40.1	4	1	1	1	
511									
512	MONTREAL	1933	BELDING CORTICELI	40.1	2	1	1	1	
513	MONTREAL	1930	GILLETTE	40.1	4..	1	1	1	
513	MONTREAL	1931		40.1	4..	1	1	1	
514	MONTREAL	1938		40.1	4	1	1	1	
515									
516									
517	MONTREAL		DEXTER SHOE						
518									
519	MONTREAL	1936		40.1	1	1	1	1	
520	MONTREAL								
521	MONTREAL, QUE.	1940		41.1	1	1	5	1	1
522									
523	MONTREAL			41.2					
523	MONTREAL, QUE.	1955	EATONS	41.1	1	1	5	2	1
524	MONTREAL	1931	LEWIS BROS	40.1	2	1	1	1	
524	MONTREAL	1943	(wide 1.3 in)	40.1	2c	1	1	1	
525	MONTREAL, QUE.	1940	DUPUIS FRERES	41.2	1	3	5	5	1
526	MONTREAL			41.2					
527	MONTREAL, QUE.			41					
528	MONTREAL, QUE.	1973	SIMPSONS	41.1	1	1	5	2	1
529									
530	MONTREAL, QUE.	1973	EATONS	41.1	1	1	5	2	1
531									
532	MONTREAL	1942	TRIANGLE MILLS	40.5	10	1	1	1	
533	MONTREAL		DUPUIS FRERES						
534									
535	Montreal, Que.	1960	DALMAR PRODUCTS	41.2	1	3	7	0	2b
601	WINDSOR	1926		40.2	10	6b	4	3	
601	WINDSOR	1931		40.2	10	6a	4	3	
602	WINDSOR	1930		40.1	1a.	1	1	1	
602	WINDSOR	1931	BAYER ASPIRIN	40.1	1a.	1	1	1	
602	WINDSOR	1943	BAYER ASPIRIN	40.1	1c	1	1	1	
603	WINDSOR, ONT.	1936		41.1	1	1	3	1	3
621	SIMCOE			40					
625	MONTREAL, QUE.	1940		41.2	1	2	2	3	2
631	PARIS	1934		40.1	1a	1	1	1	
636	DON MILLS, ONT.	1968	OXFORD PRESS	41.1	1	1	4	1	1
637	DON MILLS, ONT.	1968	GRAND & TOY						
638	DON MILLS, ONT.	1972		41.1	1	1	2	1	1
638	DON MILLS, ONT.	1973		41.1	1	1	2	2	1
639									
640									
641	REXDALE, ONT.								

700	WINNIPEG, MAN		41.1						
701	WINNIPEG		41.1	1	1	2	1	1	
702	WINNIPEG		40						
702	WINNIPEG	1931	40.1	1a	1	1	1		
703	WINNIPEG	1933	40.1	1a	1	1	1		
703	WINNIPEG	1952	40.1	1c	1	1	1		
703	WINNIPEG, MAN.	1971	41.1	1	1	2	2	1	
704									
705	WINNIPEG								
706	WINNIPEG		40						
707	WINNIPEG		40						
708									
709	WINNIPEG		40						
710	WINNIPEG		40						
711									
712	WINNIPEG	1941	40.1	1c	1	1	1		
713	WINNIPEG	1937	40						
714	WINNIPEG		40						
715	WINNIPEG	1954	40						
715	WINNIPEG	1955	40.1	1a.	1	1	1		
716	WINNIPEG								
717	WINNIPEG								
718	WINNIPEG	1933	40.1	1a	1	1	1		
718	WINNIPEG	1937	40						
719									
720	WINNIPEG		40						
721	WINNIPEG, MAN.	1955	41.1	1	1	1	2	3	
722	WINNIPEG		40						
723									
724	WINNIPEG		40						
725									
726	WINNIPEG		40						
727									
728	WINNIPEG		40						
729	WINNIPEG	1945	40.2	10 6c	4	3			
729	WINNIPEG, MAN.	1957 CANADA POST	41.3	1 4	8	3	1		
729	WINNIPEG, MAN.	1968 CANADA POST	41.3	1 4	8	3	1		
730									
731	WINNIPEG	1948	40.1	1a	1,	1	1		
732	WINNIPEG, MAN.	1941 EATONS	41.1						
733	WINNIPEG, MAN.	1975	41.1	1	1	1	2	1	
734	WINNIPEG	1954 CANADA POST	40	1	1	1	1		
735									
736	WINNIPEG, MAN.		41						
737	WINNIPEG, MAN.		41						
737	WINNIPEG	1941	40.1	1a	1	1	1		
738	WINNIPEG, MAN.		41						
739	WINNIPEG, MAN.	1957 CANADA POST	41.3	1 4	1	4	1		
740	WINNIPEG, MAN.		41						
741	WINNIPEG		40						
742									
743									
744	WINNIPEG	HBC							
745									
746	WINNIPEG, MANITOBA		41						

747									
748	WINNIPEG, MAN.	1962	HBC	41.1	1	1	2	2	1
749	WINNIPEG, MANITOBA	1952		41					
750	WINNIPEG, MAN.	1962		41.1	1	1	2	2	1
751	WINNIPEG, MAN.	1966	EATONS	41.1	1	1	4	1	1
751	WINNIPEG, MAN	1972		41.1	1	1	4	1	1
752				41					
752	WINNIPEG, MAN.	1955		41.1	1	1	5	2	1
753									
754									
755									
756									
757									
757	WINNIPEG, MAN,	1970		41.1	1	1	2	2	1
760									
761									
762									
763									
764									
765									
766									
767									
811	MOOSE JAW	1954		40.2	10	6c	4	3	
812	MOOSE JAW, SASK.	1954		41.1	1	1	3	2	1
841	REGINA	1933		40.2	10	6b.	4	3	
841	REGINA, SASK.	1939		41.1	1	1	3	1	1
841	REGINA, SASK.	1951		41.1	1	1	1	2	1
842	REGINA			40					
843	REGINA	1935		40.1	1b	1	1	1	
844	REGINA			40					
845	REGINA			40					
846	REGINA			40					
847	REGINA			40					
848	REGINA	1935		40.1	1b	1	1	1	
848	REGINA	1942	MY WARDROBE	40.2	10	6a	4	3	
849	REGINA	1942		40					
850	REGINA, SASK.			41					
851	REGINA	1933		40.2	10	6a	4	3	
852									
853									
854									
855									
856									
857									
858									
859									
860									
861	SASKATOON, SASK.	1937		41.1	1	1	1	1	1
861	SASKATOON, SASK.	1957		41.1	1	1	3	2	3
862	SASKATOON	1928		40.2	10	6a	4	3	
863	REGINA		SIMPSONS						
864									
865	REGINA, SASK.			41					
866									
867									
867	REGINA, SASK.	1943		41.1	1	1	5	2	1
868	REGINA, SASK.			41					

869	REGINA, SASK.									41
870										
871	REGINA, SASK.									41
872										
873	REGINA, SASK.		SIMPSONS							
874	REGINA, SASK.	1962	SIMPSONS		41.1	1	1	4	2	1
875	REGINA, SASK.	1962	SIMPSONS		41.1	1	1	2	2	1
876	REGINA, SASK.		ARMY & NAVY							
877										
878	REGINA, SASK.				41.1	1	1	7	2	1
879	REGINA, SASK.		SIMPSONS		41.1	1	1	7	2	1
880	REGINA		ARMY & NAVY							
881	CALGARY				40					
882	REGINA, SASK.				41					
883										
884	REGINA, SASK.				41					
900										
901	EDMONTON	1932			40.2	10	6c	4	3	
901	EDMONTON, ALTA.	1947			41.1	1	1	1	2	1b
902	EDMONTON, ALTA				41					
902	EDMONTON	1936			40.1	1a	1	1	1	
903										
951	VANCOUVER	1943			40.1	5	2c	2	3	
958	VANCOUVER, B.C.	1950			41					
959										
960										
961	VANCOUVER	1928			40.4	10	2b	4	3	
961	VANCOUVER	1936	BOGARDUS, WICKENS		40.2	10	6a.	4	3	
962										
963										
963	VANCOUVER	1935	BIRKS		40.1	1a	1	1	1	
964	VANCOUVER				40					
965	VANCOUVER	1950	WOODWARD STORES		40.1	1a	1	1	1	
965	VANCOUVER, B.C.	1961			41.1	1	1	2	2	1
966	VANCOUVER, B.C.	1972			41.1	1	1	4	2	2
967	VANCOUVER				40.2	10	6c	4	3	
967	VANCOUVER	1936			40.2	10	6a.	4	3	
967	VANCOUVER	1942	HARRIS PAINTS		40.2	10	6c	4	3	
968	VANCOUVER, B.C.	1937			41.1	1	1	7	1	1
968	VANCOUVER, B.C.	1946	RICHMONDPOSTAL STA		41.1	1	1	8	1	1
969	VANCOUVER, B.C.		SIMPSONS							
970	VANCOUVER, B.C.		SIMPSONS							
971	VANCOUVER, CANADA		SIMPSONS		41					
972	VANCOUVER, B.C.		SIMPSONS							
973	VANCOUVER, B.C.		SIMPSONS							
974	VANCOUVER, B.C.		REGAL STATIONERY							
975	VANCOUVER, B.C.		CANADA POST		41					
980										
981	VANCOUVER STATION/SOUTH BURNABY				40					
981	VANCOUVER	?	H.B.C.		40.2	10	6b	4	3	
981	VICTORIA, B.C.	1927			40.1	1a	3	1	2	
982	VICTORIA	1935			40.2	10	6a.	4	3	
982	VICTORIA, B.C.	1941			41.1	1	1	8	1	1
983	VICTORIA, B.C.	1937	PROV OF B.C.		41.1	1	1	3	1	2
983	VICTORIA, B.C.	1939	PROV OF B.C.		41.1	1	3	1	1a	2